

Spare Parts Catalogue

TX10-16

Stackers

Valid for machine code: HA310000000
Revision: 0 (10/2006)

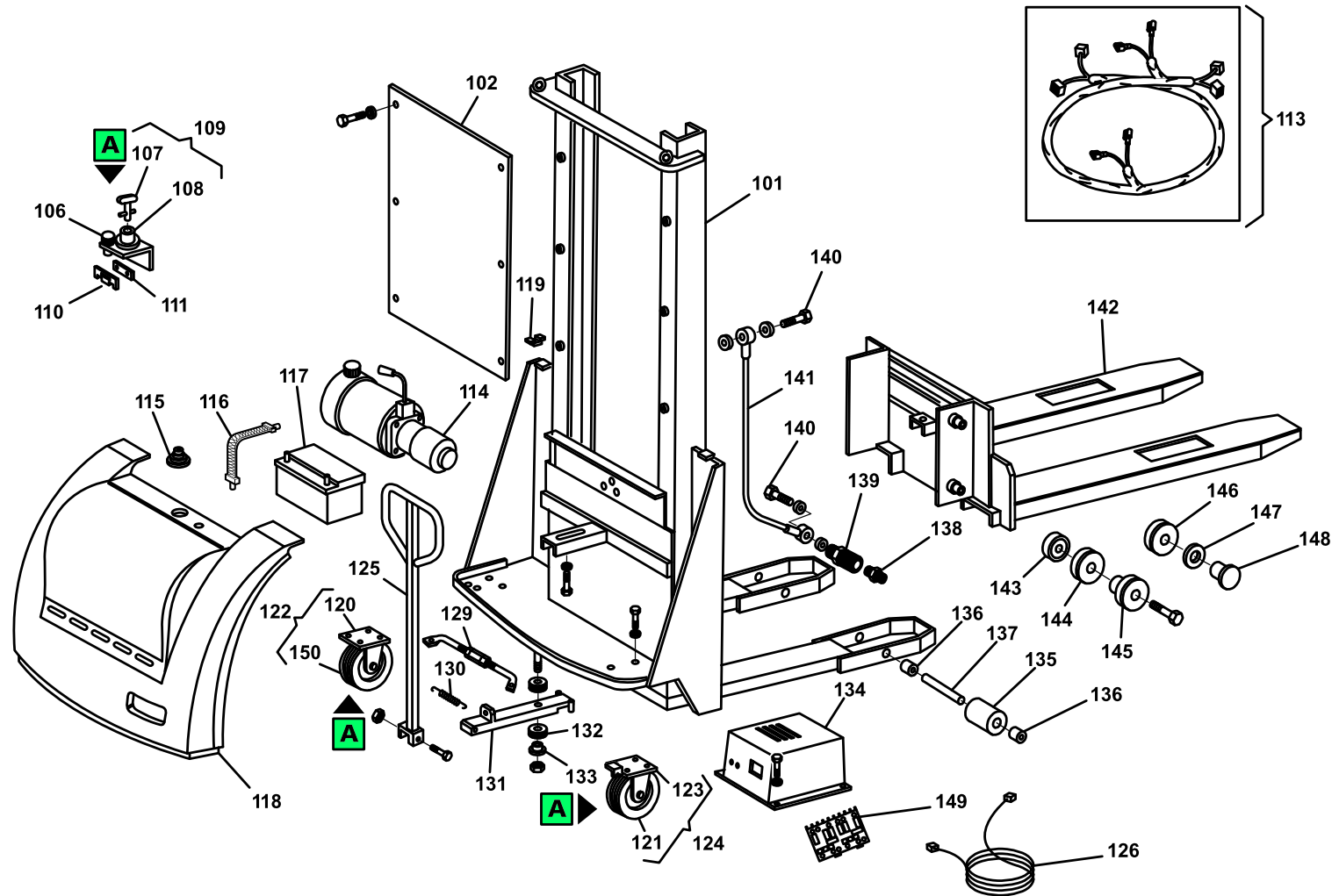

POSITION	PART NUMBER	DESCRIPTION	NOTES
101	V0201030114-PRAMAC	TELAIO TX 10/16 VERN. VERDE PRAMAC	
102	S0310018006	PLEXIGLASS GUARD TX10/20-16 TX12/29-35 GX12/29-35-38 GX10/16 FX12/29-35-38 G10 VERS.2	
106	G070625	FUSE HOLDER SCREW CAP + FUSE 6.3A	
107	G075220	KEY x BATTERY DISCONNECTING SWITCH	
109	G075102	BATTERY DISCONNECTING SWITCH 1 POLE	
110	G077540	FUSE 160A (RFM REGHEL)	
111	G070603	FUSE HOLDER x FUSE 160Amp	
113	S0208020116	ELECTRIC WIRING CABLES TX	
114	▲ G081028	HYDRAULIC POWER PACK '06 TX10	Attention: this item is valid for machines produced until 14/07/2008 Interchangeable: YES
114	▲ G081037	HYDRAULIC UNIT TX10 '08	Attention: this item is valid for machines produced from 14/07/2008 Interchangeable: YES
115	G052002	RUBBER BELLOWS (FOR STACKERS)(0-RAB/010)	
116	G000103	BATTERY ELASTIC WEBBING TX10	
117	G099300024	STARTER BATTERY 12 V - 70 Ah C/20 DIM. MAX 275x175x190	
118	▲ S0200018011	HOOD GUARD TX 10	Attention: this item is valid for machines produced until 14/09/2011 Interchangeable: NO
118	▲ S000035904	BONNET COVER TX 10 '11	Attention: this item is valid for machines produced from 14/09/2011 Interchangeable: NO
119	G034903	CAGE NUT M8 ZN	
120	G053402	SWIVELLING HEAVY STAND FOR WHEEL D200x50	
121	S0014010233	POLYURETHANE WHEEL /ALL D200x50 LAG + BEARINGS 6204	
121	S0002010169	Rubber Wheel D200 (model No. Ea200bh-65a Lifter)+bearing	
122	G053103	RUBBER WHEEL D200x50 HEAVY SUPPORT	
122	G053306	POLYURETHANE WHEEL C D200x50 HEAVY SUPPORT	
123	G053401	SWIVELLING HEAVY STAND FOR WHEEL D200x50 + BRAKE	
124	G053305	POLYURETHANE WHEEL C D200x50 HEAVY SUPPORT WITH BRAKE	
124	G053102	RUBBER WHEEL D200x50 HEAVY SUPPORT + BRAKE	
125	S0204020113	HANDLE PAINTED TX 10-12	
126	PTB00019	CABLE 3x0.75 IEC SK	
129	P0BR00001	HANDLE LINKAGE COMPLETE ARM TX10	
130	G001109	TRACTION SPRING P.49 HOOKS AT 90 DEGREES.	
131	S0202010056	HANDLE x TX10 PAINTED	
132	S0202010031	HANDLE BEARING TM	
133	S0204025010	LOWER LARGE WASHER TMC	
134	▲ G099300057	OPEN FRAME BATTERY CHARGER 15A-12V X TX 10	Attention: this item is valid for machines produced with serial number until LLI0035821 Interchangeable: YES

POSITION	PART NUMBER	DESCRIPTION	NOTES
134	 S000035910	HIGH FREQUENCY BATTERY CHARGER S.P.E. 12-24V 10A TX10 SUPPORT + CABLE IEC-SCHUKO 2m	Attention: this item is valid for machines produced with serial number from LLI0035821 Interchangeable: YES
135	S0202020029	NYLON ROLLER D82x70 + BEARINGS	
136	S0302016026	ROLLER SPACER SING.TX-GX (L.15) ZINC	
137	S0302015025	CLEVIS PIN TX/GX/LX "BURNISHED"	
138	G084103	MALE/MALE ADAPTATORS 3/8"	
139	G085003	FLOW CONTROL VALVE 3/8"	
140	G084001	SCREW PERFORATE (4 HOLES) 3/8" L 29 -0,5/0 CH22	
141	G083002	TUBO EN853 2SN 3/8" L=880 OCCHIO 3/8" - OCCHIO 3/8" - H OCCHIO 17,5+/-0,2 FORO 3/8	
142	S0207010034	COMPLETE FORK PAINTED TX10/16-20	
143	G010151	BEARING 6305 (25-62-17)	
144	S0207016006	SLIDING ROLL FORK TMC 10/16	
145	S0207018001	FORK ROLLER GUIDE GX/TX	
146	G019306	BEARING D70 (CSF.002)	
147	G019315	CONTRAST PLATE '01	
148	G019314 + G019315	DESCRIPTION N/A	
149	PTB00004	EL. BOARD FOR BATTERY CHARGER	

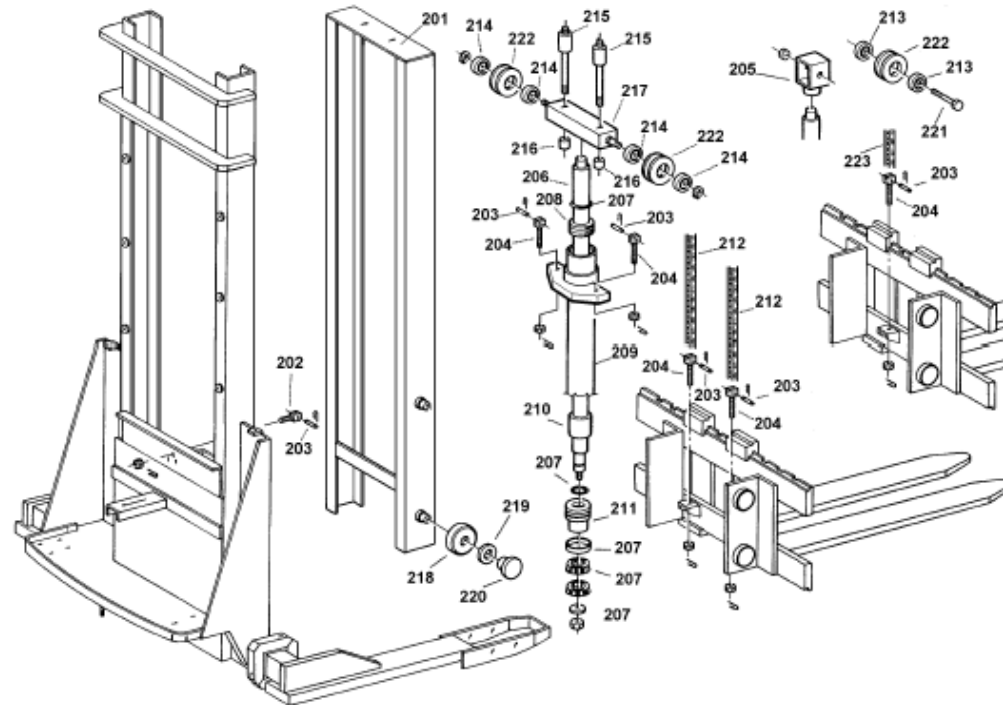

POSITION	PART NUMBER	DESCRIPTION	NOTES
202	S0307015015	SHORT CHAIN HOLDER TE-TM-L/VT ZINC PLATED	
203	G062104	FLAYER CHAIN PIN BL544 D6x29	
204	S0300185013	CHAIN HOLDER LX 12-14-16 ZINC PLATED	
205	S0306051022	CAST IRON PULLEY HOLDER TE-TM-L PAINTED	
206	S000035306	CYLINDER ROD TX-GX 10/16	
207	G090015	GASKET SET TMC16/20 G10-29	
208	S0206011001	CYLINDER BUSHING TMC 10/16-20	
209	S0206010063	COMPLETE CYLINDER TX-GX 10/16 PAINTED	
210	S0206016008	CYLINDER SPACER L.35 TE-TM	
211	S000035304	CYLINDER PISTON TX-GX 10/09-16-20	
212	G062020	FLAYER CHAIN STUB BL534-129P	
213	G010401	BEARING 6204 2RS (20-47-14)	
221	S0306055043	CAST IRON PULLEY PIN HOLDER BURNISHED	
222	S0300158042	MACHINED PULLEY (CAST IRON) FOR STACKER 12Q SINGLE CHAIN	
223	G062024	FLAYER CHAIN STUB BL534-79P	

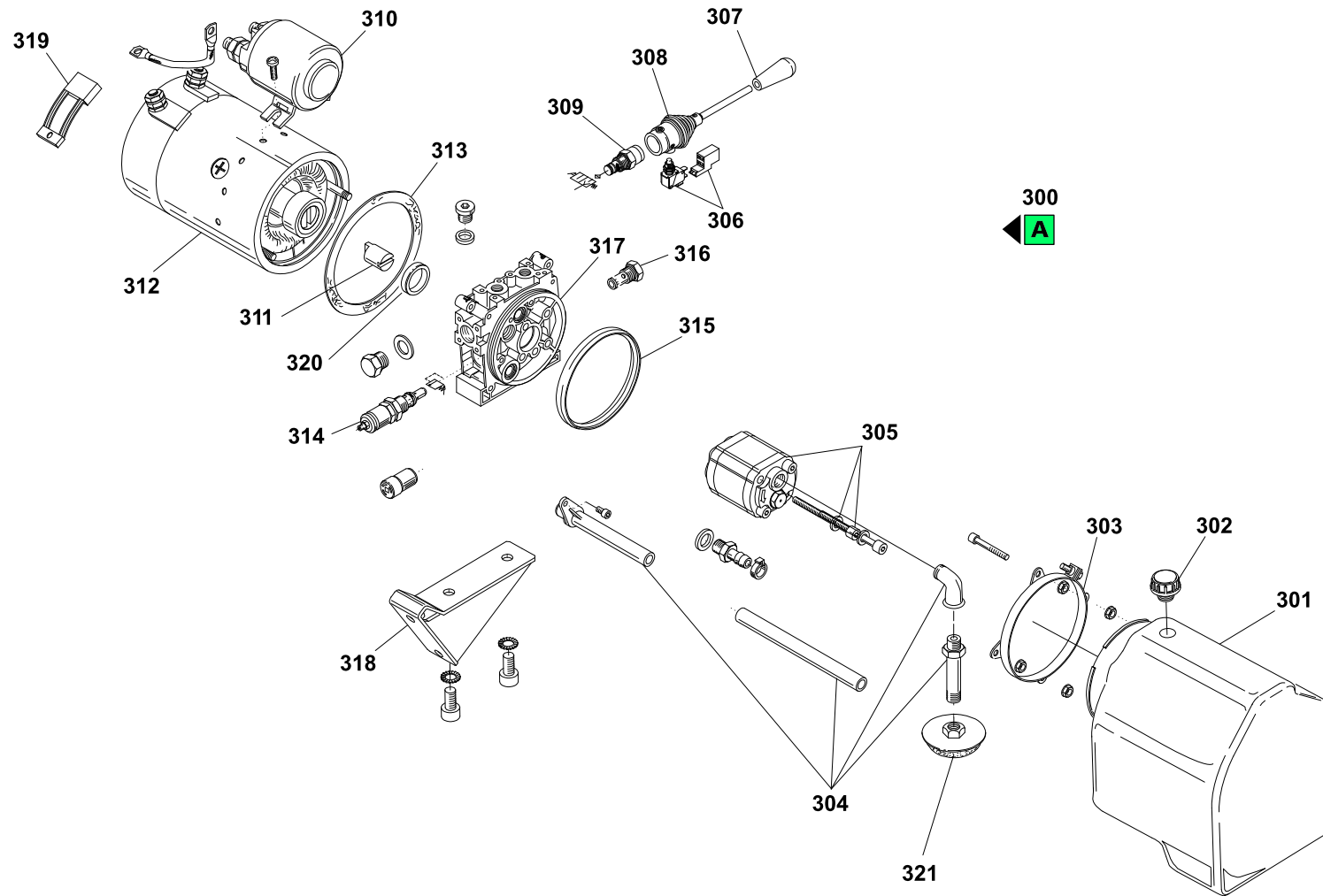

POSITION	PART NUMBER	DESCRIPTION	NOTES
300	G081028	HYDRAULIC POWER PACK '06 TX10	
301	PCY61214500	RESERVOIR BOTTLE	
302	PCY49154500	OIL CAP TANK TX HYDR-APP	
303	PCY25004800	BAND FOR HYDRAULIC UNIT H	
304	PCY12002	KIT TUBI TX HYDR-APP	
305	PCY17050067	KIT POMPA "F" PHC 1-1,7 cm3/g DX+V	
306	PCY46109900	MICROSWITCH	
307	PCY49104600	POMELLO CENTRALINA HYDR-APP	
308	PCY25005800	HYDRAULIC POWER PACK COMPLETE LEVER	
309	PCY20023000	VALVOLA TX10/12	
310	G082180	RELAY 12V. 80 AH	
311	PCY60410600	GIUNTO A PENNA PER "MC" CON MOTORE ELETTRICO 2.05-2.2Kw E POMPE Gr.1	
312	PCY24011500	ENGINE 12V FOR TX10 CONTROL UNIT	
313	PCY61200100	GASKET FOR HYDRAULIC UNIT H	
314	PCY21000001	VALVOLA MAX 50-210 BAR	
315	PCY61212400	HYDRAULIC UNIT O-RING HX	
316	PCY20020400	HYDRAULIC UNIT RETENTION VALVE HX	
317	PCY71013005	CENTRAL FLANGE	
318	PCY17010067	FIXING TX	
319	PCY00004056	BRUSH KIT GX/10/12 TX12	
320	PCY60507900	SPACER FOR HYDRAULIC UNIT H	
321	PCY49122100	FILTER	

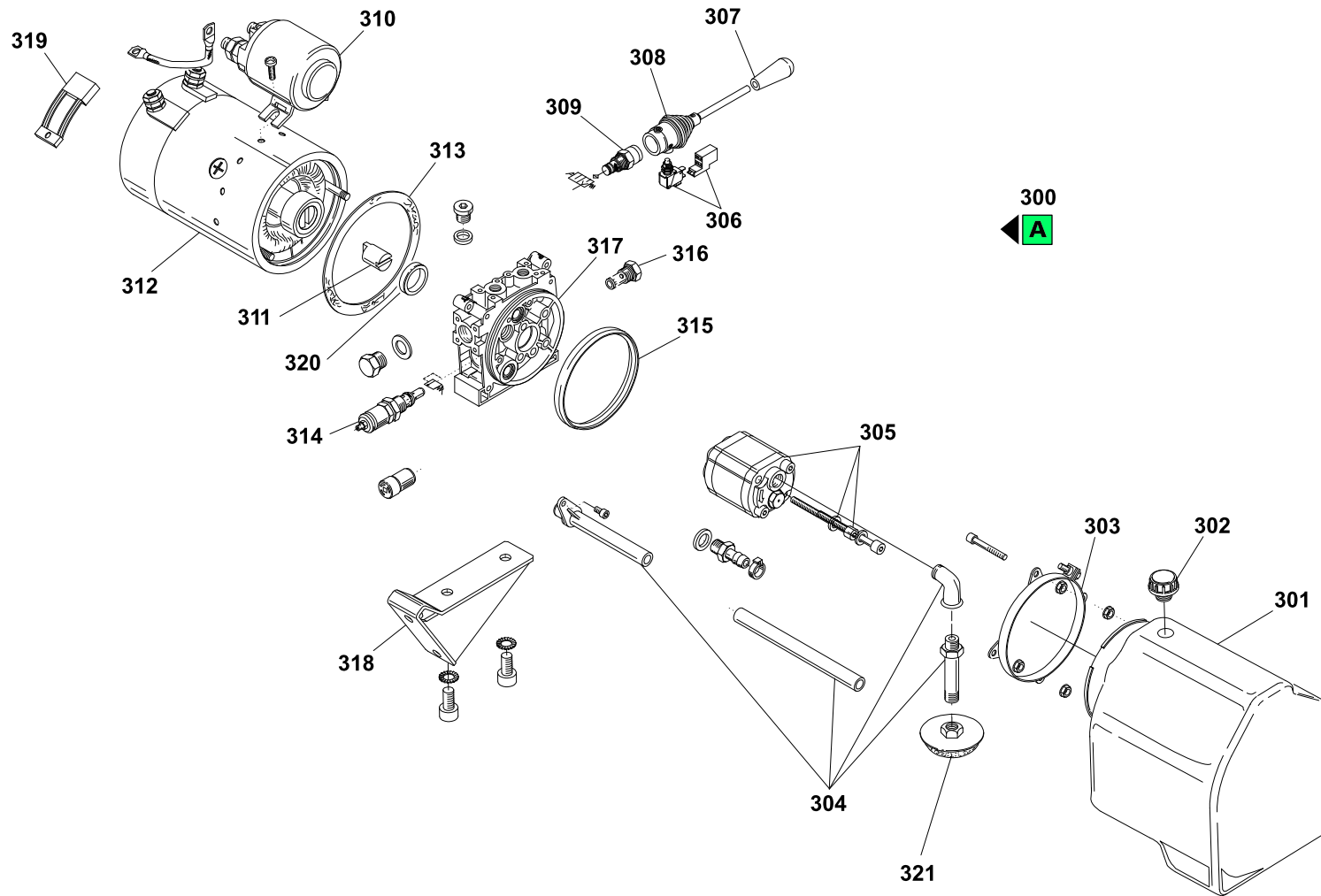

POSITION	PART NUMBER	DESCRIPTION	NOTES
300	G081037	HYDRAULIC UNIT TX10 '08	
301	PCY61214500	RESERVOIR BOTTLE	
302	PCY49154500	OIL CAP TANK TX HYDR-APP	
303	PCY25004800	BAND FOR HYDRAULIC UNIT H	
304	PCY12002	KIT TUBI TX HYDR-APP	
305	PCY00035	POMPA CENTRALINA	
306	PCY46109900	MICROSWITCH	
307	PCY49104600	POMELLO CENTRALINA HYDR-APP	
308	PCY25005800	HYDRAULIC POWER PACK COMPLETE LEVER	
309	PCY20023000	VALVOLA TX10/12	
310	G082180	RELAY 12V. 80 AH	
311	PCY60410600	GIUNTO A PENNA PER "MC" CON MOTORE ELETTRICO 2.05-2.2Kw E POMPE Gr.1	
312	PCY24011500	ENGINE 12V FOR TX10 CONTROL UNIT	
313	PCY61200100	GASKET FOR HYDRAULIC UNIT H	
314	PCY21000001	VALVOLA MAX 50-210 BAR	
315	PCY61212400	HYDRAULIC UNIT O-RING HX	
316	PCY20020400	HYDRAULIC UNIT RETENTION VALVE HX	
317	PCY71013005	CENTRAL FLANGE	
318	PCY17010067	FIXING TX	
319	PCY00004056	BRUSH KIT GX/10/12 TX12	
320	PCY60507900	SPACER FOR HYDRAULIC UNIT H	
321	PCY49122100	FILTER	