

Spare Parts Catalogue

MX510

Stackers

Valid for machine code: HB105000000
Revision: 0 (10/2006)

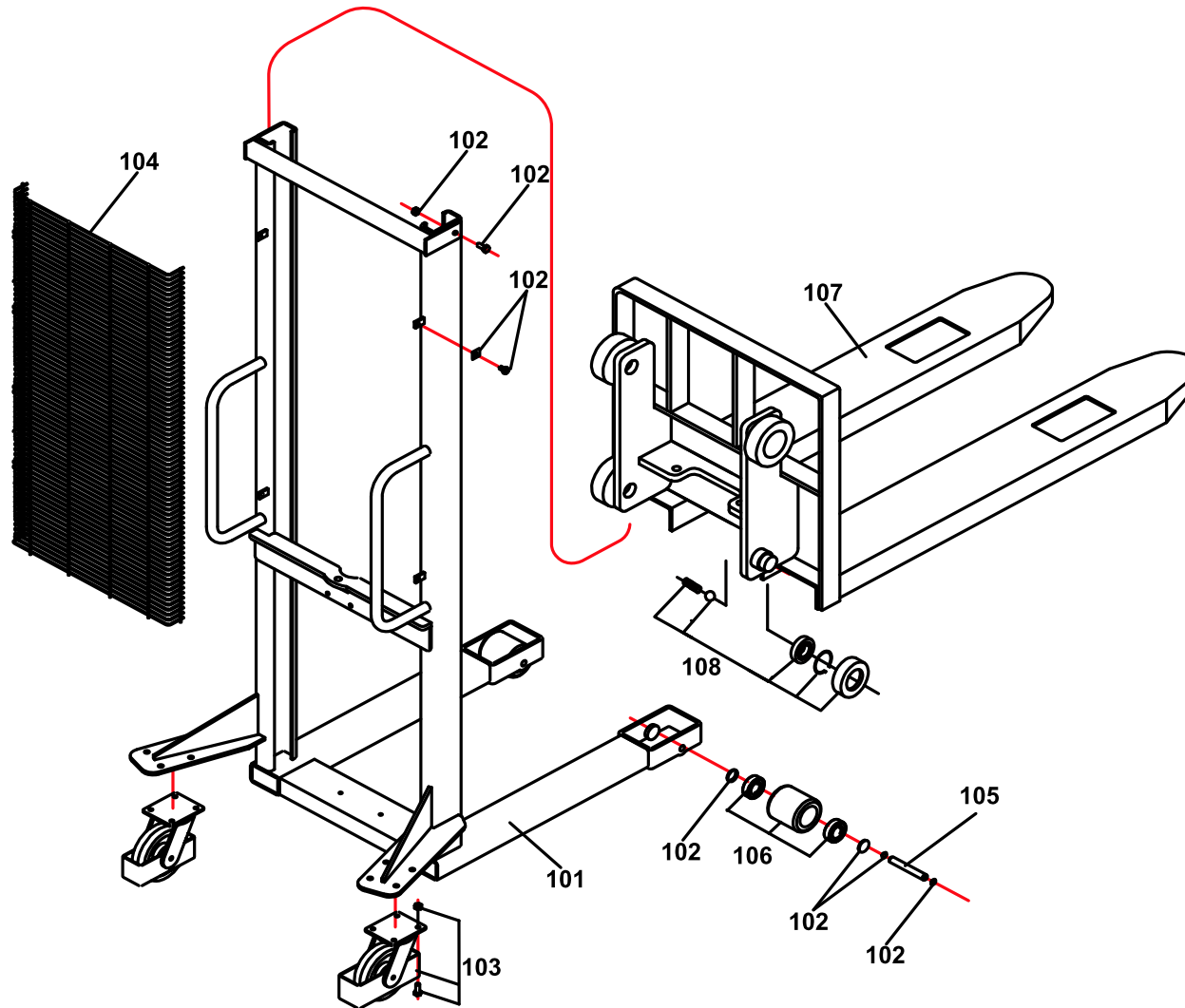

POSITION	PART NUMBER	DESCRIPTION	NOTES
101	PCNSDJA006	FRAME	
102	-	DESCRIPTION N/A	
103	PCNSDJABC018	COMPLETE WHEEL	
104	PCNSDJA007	PROTECTIVE GRID	
105	PCNSDJABC019	PIN	
106	PCNSDJABC020	COMPLETE ROLLER	
107	PCNSDJAB008	FORKS	
108	PCNSDJABC021	COMPLETE SLIDING ROLLER	

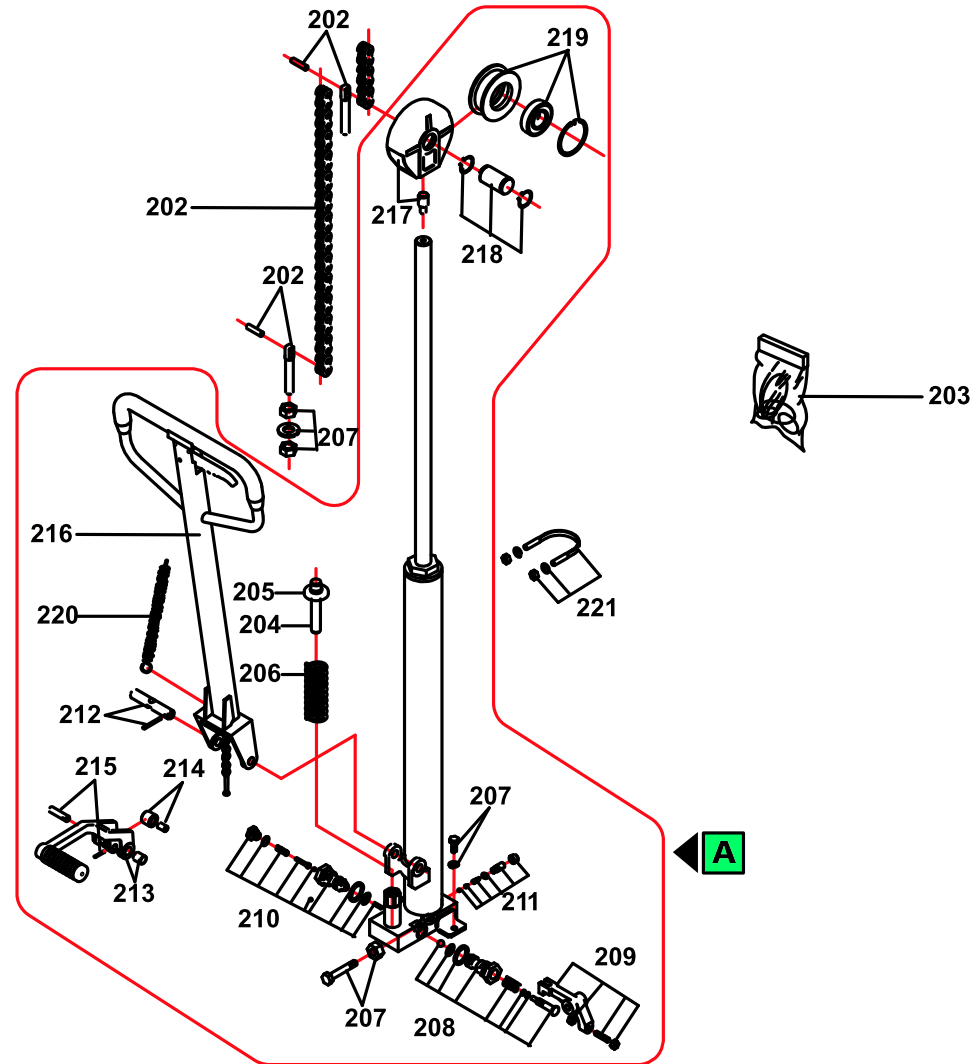

POSITION	PART NUMBER	DESCRIPTION	NOTES
201	PCNSDJA001	COMPLETE HYDRAULIC UNIT	
202	PCNSDJA002	CHAI NTIGHTENER	
203	PCNSDJABC001	GASKET KIT	
204	PCNSDJABC002	PISTON	
205	PCNSDJABC003	SPRING GUIDE	
206	PCNSDJABC004	SPRING	
208	PCNSDJABC006	COMPLETE VALVE	
209	PCNSDJABC007	PEDAL	
210	PCNSDJABC008	COMPLETE VALVE	
211	PCNSDJABC009	COMPLETE VALVE	
212	PCNSDJABC010	PIN	
213	PCNSDJABC011	PEDAL	
214	PCNSDJABC012	COMPLETE ROLLER	
215	PCNSDJABC013	PIN	
216	PCNSDJABC014	COMPLETE TOWBAR	
217	PCNSDJAB003	PULLEY HOLDER	
218	PCNSDJAB004	PIN	
219	PCNSDJAB005	COMPLETE PULLEY	
220	PCNSDJABC015	TOWBAR SPRING	
221	PCNSDJABC016	CYLINDER BRACKET	