

Spare Parts Catalogue

HX10E 1150x680 POLY.I-GOMMA-PRAMAC

High lift pallettruck

Valid for machine code: EE0440V0000

Revision: 0 (12/2021)

HX10E 1150x680 POLY.I-GOMMA-PRAMAC - Machine code:
EE0440V0000

Spare Parts Catalogue HX10E 1150x680 POLY.I-GOMMA-PRAMAC -
Revision: 0 (12/2021)

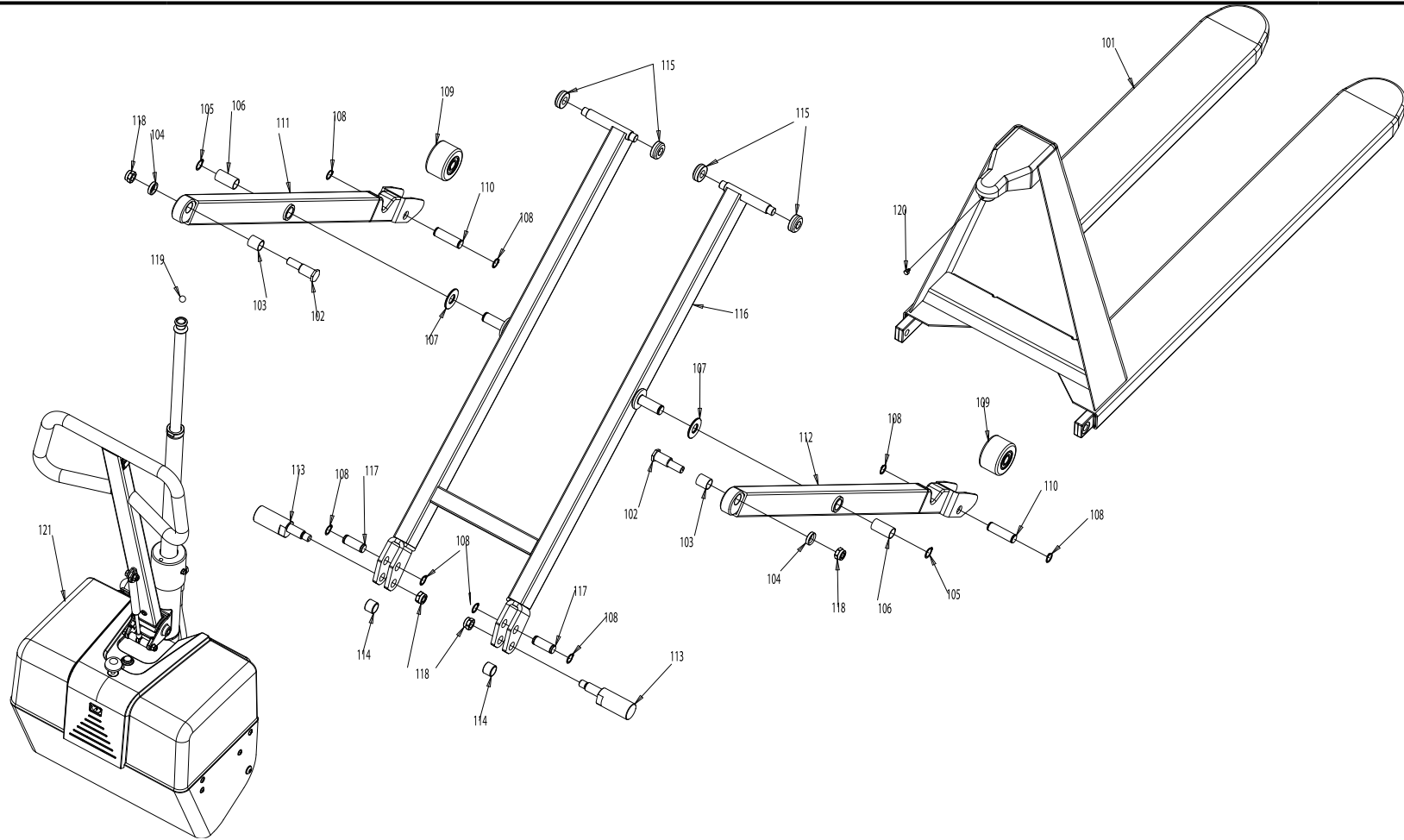

POSITION	PART NUMBER	DESCRIPTION	NOTES
101	V000017013-PRAMAC	FRAME HX10M/E L.680 GREEN PAINTED PRAMAC	
102	S0041215026	ADJUSTING CAM HL10E BURNISHED	
103	G016395	SELF-LUBRICATING BUSHING Fe 22x26x28	
104	S0041218009	ARMS SPACER HL10M/E	
105	G042122	OUTER SEEGER 7435 E 22	
106	G016304	SELF-LUBRICATING BUSHING Fe 22x26x50	
107	S0041218010	VERTICAL ROD NYLON SPACER HL10M/E	
108	G042120	OUTER SEEGER 7435 E 20	
109	S0042070113	INJECTED POLYURETHANE ROLLER D80x50 + BEARINGS	
110	S0041215025	ROLLER PIN HL10E BURNISHED	
111	V000017070-9005	PAINTED LEFT ARM HX	
112	V000017069-9005	PAINTED RIGHT ARM HX '09	
113	S000017045	STABILIZING ECCENTRIC HX10M/E '10	
114	S0041016003	CAM SPACER HL10M/E	
115	S0041218008	GUIDE ROLLER HL10E	
116	V000069000-9005	MAST HX10M/E 680 '09 PAINTED	
117	S0041015002	PIN CROSS HL10M/PED.L-K20 BURNISHED	
118	G034416	LOW-PROFILE SELF-LOCKING NUT 7474 M16 ZN	
119	G016103	BALL 9/16" (mm14,288) BALL 2	
120	G023300	FLANGED HEX HEAD TRILOBURAL SCREW M6x8 UNI 8111	
121	G081052	HYDRAULIC POWER UNIT HX10E II Ed.	

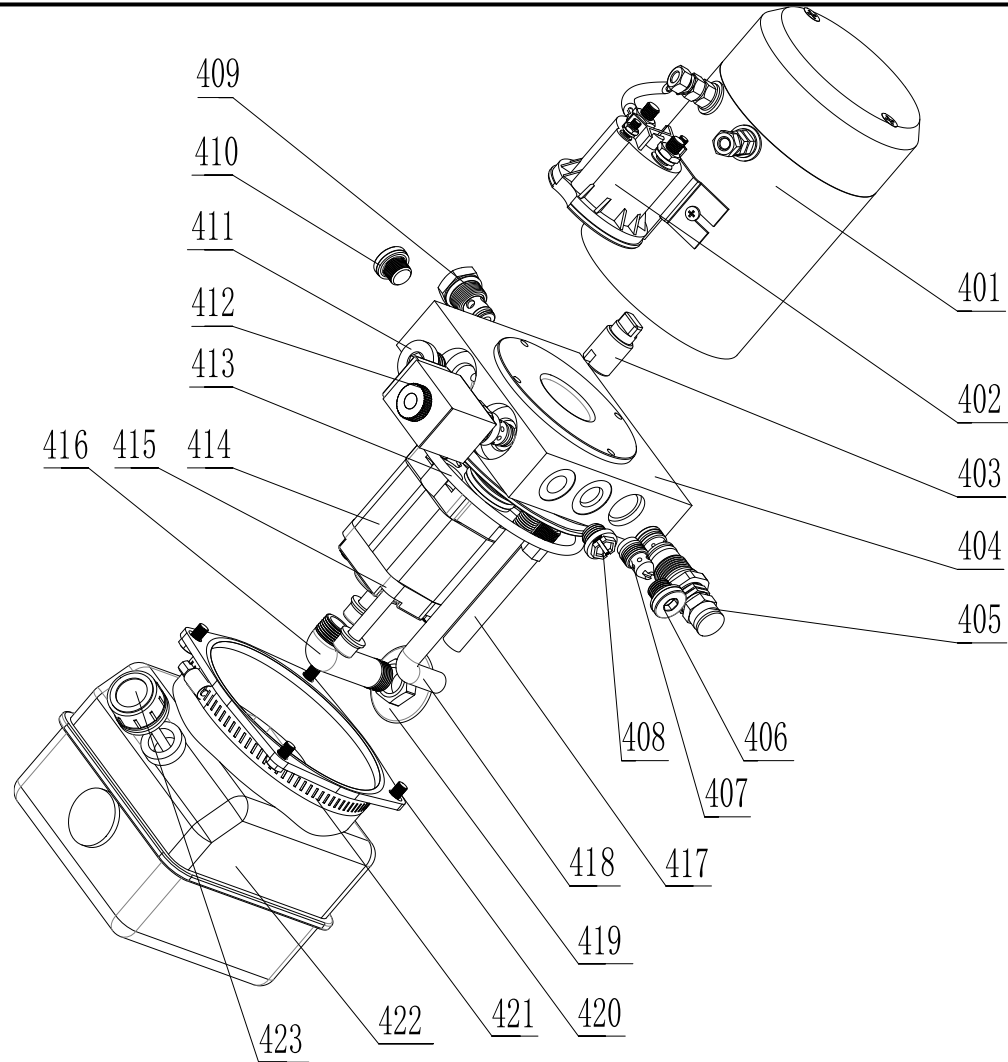

POSITION	PART NUMBER	DESCRIPTION	NOTES
400	G081052	HYDRAULIC POWER UNIT HX10E II Ed.	
401	PCV00017	DC MOTOR	
402	PCV00018	RELAY STARTER	
403	PCV00002	COUPLING PIN	
404	PCV00019	MANIFOLD	
405	PCV00020	RELIEF VALVE	
406	PCV00021	METAL PLUG	
407	PCV00005	COMPENSATED VALVE	
408	PCV00022	PLASTIC PLUG	
409	PCV00014	CHECK VALVE	
410	PCV00023	METAL PLUG	
411	PCV00024	METAL PLUG	
412	PCV00025	VALVE	
413	PCV00026	O-RING	
414	PCV00027	GEAR PUMP	
415	PCV00028	HEXAGONAL SOCKET HEAD CAP SCREW M8X90	
416	PCV00029	SUCTION PIPE	
417	PCV00030	RETURN PIPE	
418	PCV00031	RETURN PIPE	
419	PCV00032	SUCTION FILTER	
420	PCV00033	PHILLIPS + HEX HEAD SCREW M6X12	
421	PCV00034	CLAMP	
422	PCV00035	PLASTIC TANK	
423	PCV00036	BREATHER CAP 3/8"	
424	PCV00038	METAL PLUG	

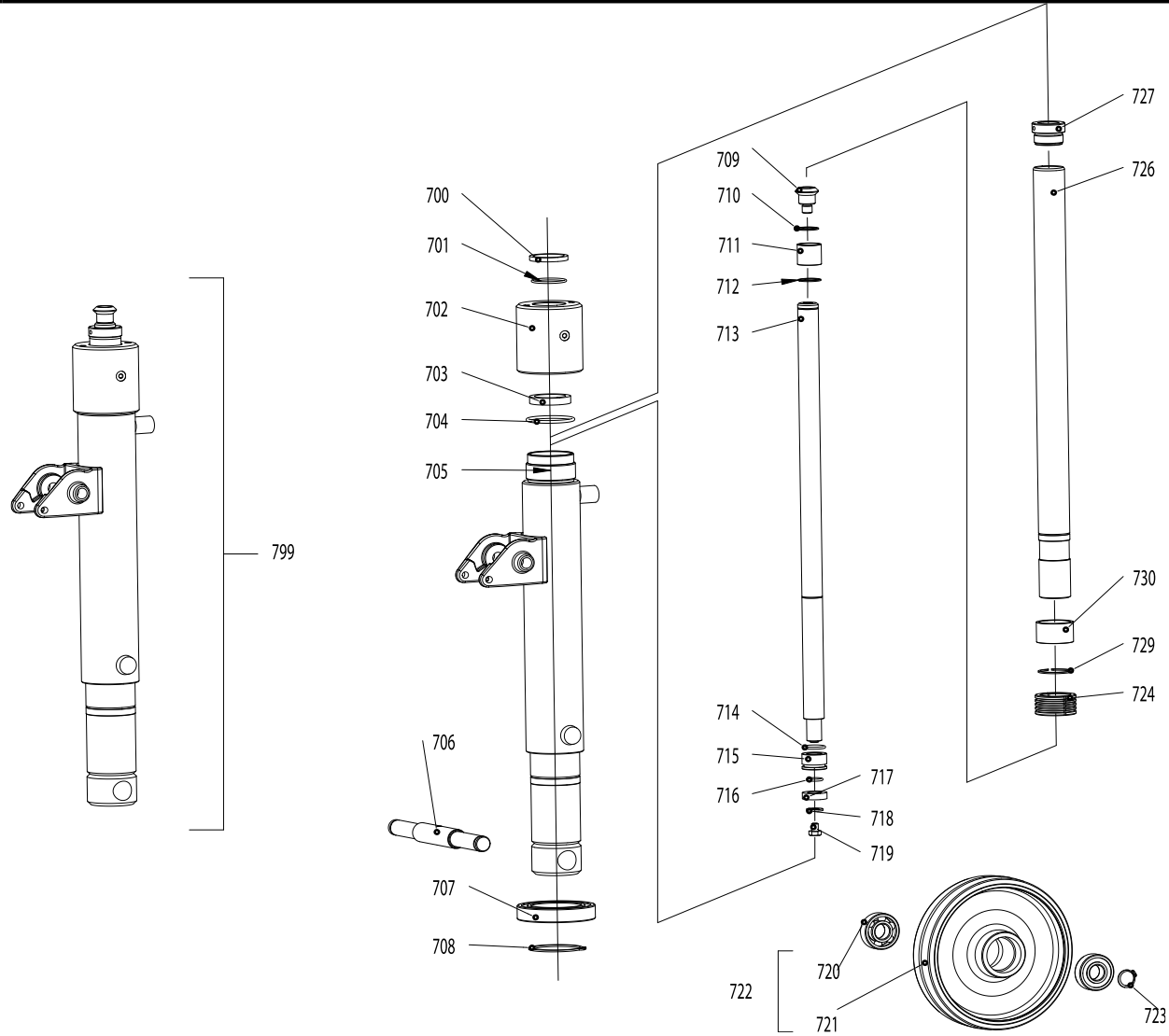

POSITION	PART NUMBER	DESCRIPTION	NOTES
700	G098107	ROD WIPER 38-46-6	
701	G095034	O-RING Ø 37.77x2.62 NBR 70	
702	S000017513	CYLINDER BUSHING HX10E '13	
704	G095035	O-RING Ø 55.56x3.53 NBR 70	
705	S000071036	DESCRIPTION N/A	
706	S000034025	WHEEL AXIS GS	
707	G010220	BEARING 6012 RS(60-95-18)	
708	G042160	OUTER SEEGER 7435 E 60	
709	S0042015008	BALL GUIDE HL10M-HL10E	
710	S000017307	SECOND ROD STOP WASHER HX10E	
711	S0042216016	SECOND STAGE SPACER HL10E NEW	
712	G042325	SEEGER SW 25 OVERSIZED (x HL10E)	
713	S000017510	SECOND ROD HX10E '13	
714	G095027	O-RING 616 (Ø15.08x2.62) NBR 70	
715	S000017511	SECOND ROD PISTON HX10E '13	
716	G099002	DRIVE RING 30-26-9,7	
717	G098040	ROD-PISTON ASYMMETRIC LIP SEAL (U) POLYURETHANE 30-20-8	
718	G041904	PLAIN WASHER 6592 10.5x21 ZN	
719	G022024	SCREW HEX-HEAD 5739 65 8.8 M8x10 ZN	
720	G010207	BEARING 6204 Z (20-47-14)	
721	G053101	RUBBER WHEEL D200 TP/GS(model no. EA200BH-65A LIFTER)	
722	S0002010169	Rubber Wheel D200 (model No. Ea200bh-65a Lifter)+bearing	
723	G042120	OUTER SEEGER 7435 E 20	
724	S000017516	CYLINDER GUIDE RING HX10E '16	
726	S0042216007	FIRST STAGE HL10E	
727	S0042211005+G098108	DESCRIPTION N/A	
729	G042100	SEEGER EXTERNAL 7435 E 38 (DIN 471)	
730	S000017300	FIRST ROD SPACER HX10E	
798	G090014	GASKET SET HL10E	
799	S000071045	COMPLETE CYLINDER HX10E II Ed.	

HX10E 1150x680 POLY.I-GOMMA-PRAMAC - Machine code:
EE0440V0000

Spare Parts Catalogue HX10E 1150x680 POLY.I-GOMMA-PRAMAC -
Revision: 0 (12/2021)

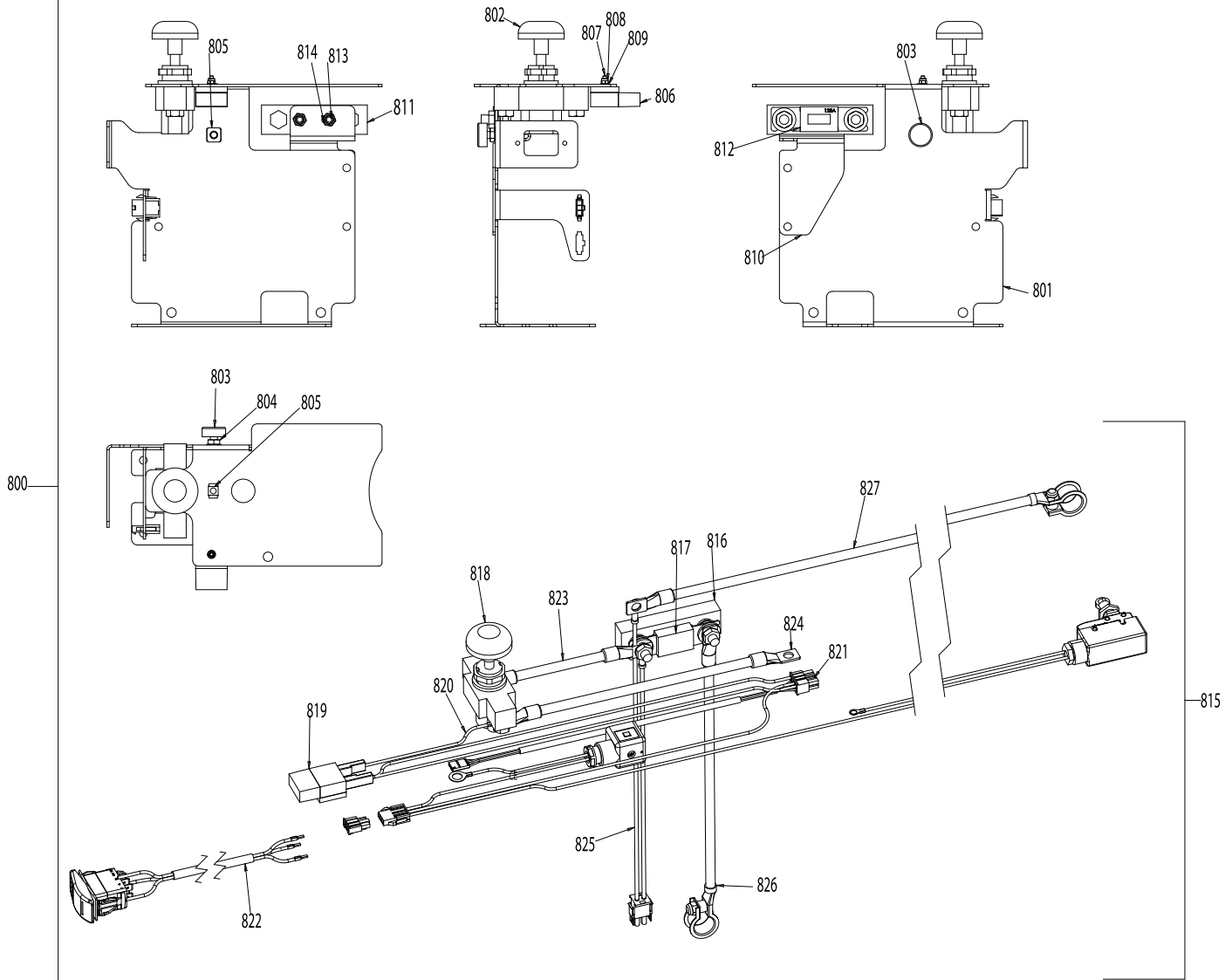

POSITION	PART NUMBER	DESCRIPTION	NOTES
800	S000071040	COMPLETE WIRED PLATE HX10E II Ed.	
801	G08906	DESCRIPTION N/A	
802	G071204	BATTERY BREAKER PUSH BUTTON 150A	
803	G052178	SILENT M BLOCK 20X08 M-20X08-M6X18-60 60 HOOD BATTERY CX14/QX20ACS	
804	G033101	DADO BASSO 5589 65 CL8 M6 ZN	
805	G034904	CAGE NUT M6 GALV. (TH. 1.8-2.6 8.3x8.3)	
806	G077471	DESCRIPTION N/A	
807	G022819	VITE TSPE 5933 8.8 M3x14 ZN	
808	G034303	DADO AUTOBL. 7473 M 3 ZN	
809	G041912	PLAIN WASHER 6592 69 3.2x7 ZN	
810	G08907	DESCRIPTION N/A	
811	G070603	FUSE HOLDER x FUSE 160Amp	
812	G077404	FUSE 125A (RFM)	
813	G022108	ALLEN SCREW 5931 67 8.8 M6x20 ZN	
814	G034404	LOW-PROFILE SELF-LOCKING NUT 7474 M 6 ZN	
815	S000071914	COMPLETE WIRING HX10E II Ed.	
816	G070603	FUSE HOLDER x FUSE 160Amp	
817	G077404	FUSE 125A (RFM)	
818	G071204	BATTERY BREAKER PUSH BUTTON 150A	
820	S000071906	DESCRIPTION N/A	
821	S000071908	DESCRIPTION N/A	
822	S000071907	TILLER WIRING HX10E II Ed.	
823	S000071911	DESCRIPTION N/A	
824	S000071910	DESCRIPTION N/A	
825	S000071909	DESCRIPTION N/A	
826	S000071912	DESCRIPTION N/A	
827	S000071913	DESCRIPTION N/A	

HX10E 1150x680 POLY.I-GOMMA-PRAMAC - Machine code:
EE0440V0000

Spare Parts Catalogue HX10E 1150x680 POLY.I-GOMMA-PRAMAC -
Revision: 0 (12/2021)

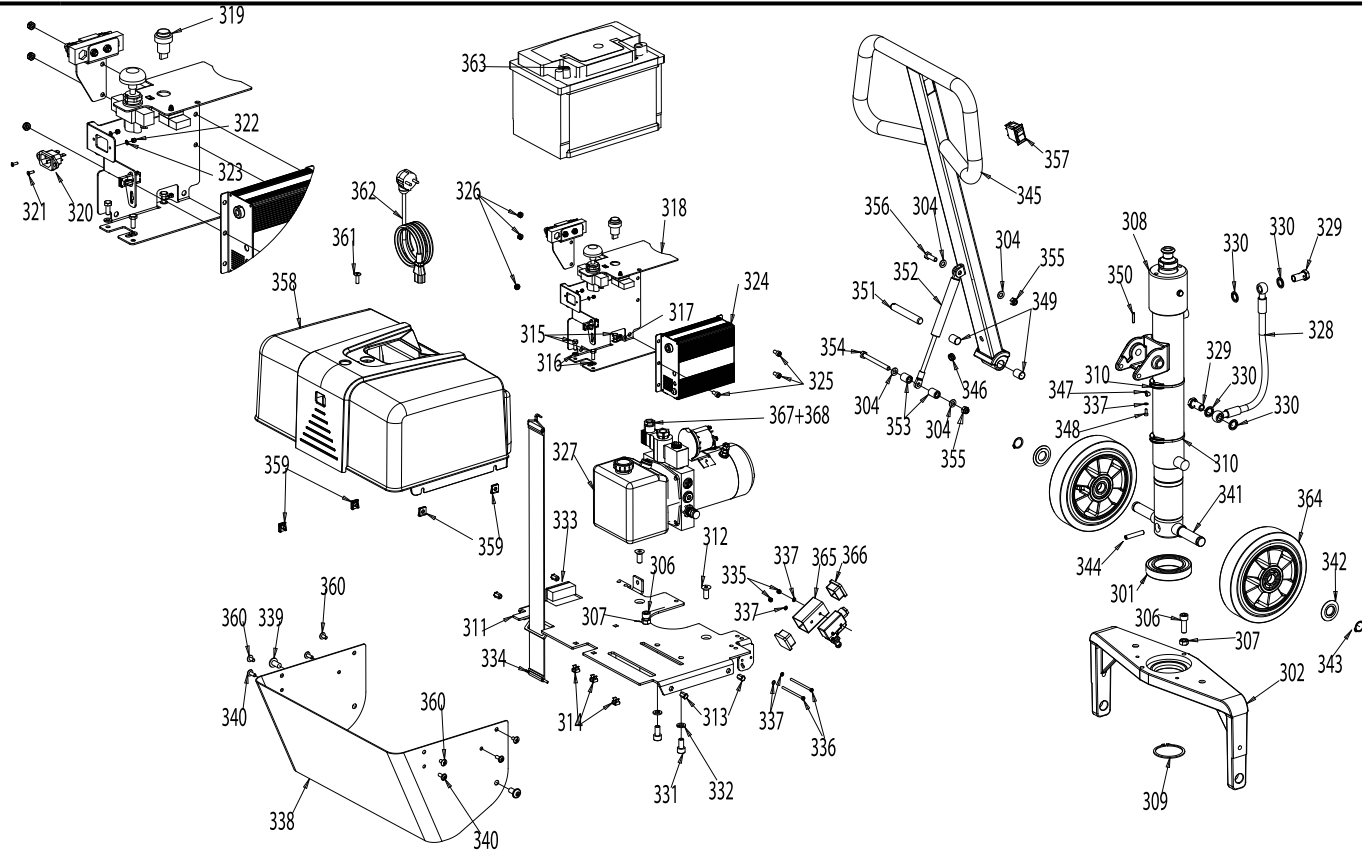

POSITION	PART NUMBER	DESCRIPTION	NOTES
301	G010220	BEARING 6012 RS(60-95-18)	
302	S000071039	MACHINED CROSS b5=680 HX10M/HX10E II Ed.	
304	G041901	PLAIN WASHER 6592 8.4x16 ZN	
306	G022114	VITE TCEI 5931-67 8.8 M10x30 ZN	
307	G032303	STANDARD NUT 5588 65 CL8 M10 ZN	
308	S000071045	COMPLETE CYLINDER HX10E II Ed.	
309	G042160	OUTER SEEGER 7435 E 60	
310	G0P707	PLASTIC CABLE-FIXING FOR CABLE Ø6	
311	V08902-9005	PAINTED BATTERY HOLDER BASE HX10E II Ed.	
312	S000021926	SELF LOCKING FLAT COUNTERSUNK HEAD SOCKET CAP SCREW 5933 8.8 M10x25 ZN	
313	G040213	THREADED STUB M6	
314	G034901	CAGE NUT M6 GALV. (TH. 3.6-4.5 8.3x8.3)	
315	G022034	SCREW HEX-HEAD 5739 65 8.8 M6x16 ZN	
316	G041104	GROWER WASHER 1751 52 D6 ZN	
317	G041608	OVERLAPPED THEETH WASHER 8842 A6 ZN	
318	S000071040	COMPLETE WIRED PLATE HX10E II Ed.	
321	G022712	HEX SOCKET C/SUNK SCREW 5933 8.8 M3x10 ZN (DIN 7991)	
322	G034303	DADO AUTOBL. 7473 M 3 ZN	
323	G041912	PLAIN WASHER 6592 69 3.2x7 ZN	
324	S000071915	BATTERY CHARGER CBHD1 12V 8A, 100-240Vac + SCHUKO PLUG + SIMPLE WIRE + IEC PLUG + IEC PANEL MOUNT + BATTERY STATUS INDICATOR x HX10E II Ed.	
325	G020640	SCREW TCEI 5931-67 8.8 M6x12 ZINC PLATED	
326	G034404	LOW-PROFILE SELF-LOCKING NUT 7474 M 6 ZN	
327	G081052	HYDRAULIC POWER UNIT HX10E II Ed.	
328	S000071041	HYDRAULIC TUBE R1AT 1/4" + BANJOS 1/4" + PLASTIC COVER L=410mm HX10E II Ed.	
329	G084000	DRILLED SCREW FOR M14 BANJO	
330	G096223	BONDED SEAL M14	
331	G022104	ALLEN SCREW 5931 67 8.8 M10x20 ZN	
332	G041105	GROWER WASHER 1751 52 D10 ZN	
333	G091314	SEAL AERSTOP PROFILE N12/A 20x20	
334	G000140	BATTERY ELASTIC WEBBING L=604 GX12 III ED. BASIC	
335	G034411	LOW SELF LOCKING NUT 7474 M 4 ZN	
336	G022119	ALLEN SCREW 5931 67 8.8 M4x70 ZN	
337	G041906	PLAIN WASHER 6592 4.3x9 ZN	
338	V08903-PRAMAC	PAINTED PROTECTION BRACKET HX10E II Ed.	
339	G025906	SELF LOCKING HEXAGON SOCKET BUTTON HEAD CAP SCREW WITH FLANGE M10X20 CLASS 10.9 ZINC	
340	G025919	SELF LOCKING HEXAGON SOCKET BUTTON HEAD CAP SCREW WITH FLANGE 8.8 M6x16 ZN (DIN 7380-2)	

POSITION	PART NUMBER	DESCRIPTION	NOTES
341	S000034025	WHEEL AXIS GS	
342	G091101	WHEEL DUSTGUARD TP 47x20 SP3.9 TELLURE	
343	G042120	OUTER SEEGER 7435 E 20	
344	G044353	ELASTIC PEG SPIROL MEDIUM DUTY ISO 8750 (DIN 7343) D8x45	
345	V000071048-9005	TIMONIERA VERNICIATA HX10E II Ed.	
346	G070265	WIRE BUSH EZ 10035 (INNER DIA. 8mm)	
347	G051929	NYLON COLLAR CN 6 BLACK	
348	G020619	ALLEN SCREW 5931-67 8.8 M4x10 ZN	
349	G016399	SELF-LUBRICATING AXLE BOX DU 14x16x20	
350	G044302	ELASTIC PEG 6873 D 4x20	
351	S000017505	HANDLE PIN HX10E	
352	G001722	GAS SPRING HX10E AMA R20 T80 252 85 400N	
353	S0042215024	GAS SPRING SPACER HL10E	
354	G022245	SCREW HEX-HEAD 5737 65 8.8 M8x85 ZN	
355	G034308	SELF-LOCKING NUT 7473 M 8 ZN	
356	G022012	SCREW HEX-HEAD 5739 65 8.8 M8x25 ZN	
357	G075203	HANDLE PUSHBUTTON SWITCH HL10E	
358	S000071900	CARTER HX10E II Ed.	
359	G034601	CLIPS M6 FOR METAL SHEET 1.9-3.0mm	
360	G024113	VITE T.LARGA TBLDT M6x12 ZN	
361	G024114	WIDE HEAD SCREW M6x20 BLACK ZINC COATED	
363	G099300019	BATTERY 60Ah 12V	
364	S0002010169	Rubber Wheel D200 (model No. Ea200bh-65a Lifter)+bearing	
365	V000071044-9005	DISTANZIALE FINE CORSA VERNICIATO b5=680 HX10E II Ed.	
366	G051210	POLYETHYLENE GILL CAP 35x35	